

REV.	DATE	DCN #	DRAWING TREE #
v1	JUN-29-10	E1000234	-
v2	14 JUL 2011	E1100351	-
-	-	-	-

- NOTES CONTINUED:**
- 5. SCRIBE, ENGRAVE (A VIBRATORY TOOL MAY BE USED), LASER MARK OR MECHANICALLY STAMP (NO INKS OR DYES) DRAWING PART NUMBER, REVISION (AND VARIANT OR TYPE IF APPLICABLE) ON NOTED SURFACE OF PART FOLLOWED ON THE NEXT LINE WITH A THREE DIGIT SERIAL NUMBER. SERIAL NUMBERS START AT 001 FOR THE FIRST ARTICLE AND PROCEED CONSECUTIVELY. USE MINIMUM 0.12" HIGH CHARACTERS. UNLESS THE SIZE OF THE PART DICTATES SMALLER CHARACTERS. EXAMPLE: DXXXXXX-VY, TYPE-XX, S/N XXX
 - 6. MACHINE ALL SURFACES TO REMOVE OXIDES AND MILL FINISH. USE OF ABRASIVE TECHNIQUES IS NOT ALLOWED.
 - 7. DO NOT USE SANDPAPER, SCOTCH BRITE OR SIMILAR PRODUCTS.
 - 8. ALL PARTS SHALL BE MANUFACTURED IN ACCORDANCE WITH LIGO SPECIFICATION E0900364
 - 9. DRILL AND TAP ONLY
 - 9.1 DRILL PILOT HOLE FOR INSERT SPECIFIED ON THE DRAWING, REFERENCE HELICOIL PRODUCT CATALOGUE, HC 2000
 - 9.2 COUNTERSINK HOLE 120°±5, REFERENCE HELICOIL PRODUCT CATALOGUE, HC 2000
 - 9.3 TAP HOLES FOR INSERT SPECIFIED ON THE DRAWING, REFERENCE HELICOIL PRODUCT CATALOGUE, HC 2000
 - 9.4 REMOVE ALL CHIPS
 - 9.5 GAGE THREADS WITH GAGE TOOL FOR INSERT SPECIFIED IN DRAWING, REFERENCE HELICOIL PRODUCT CATALOGUE, HC 2000 AND AS PER AGREED INSPECTION

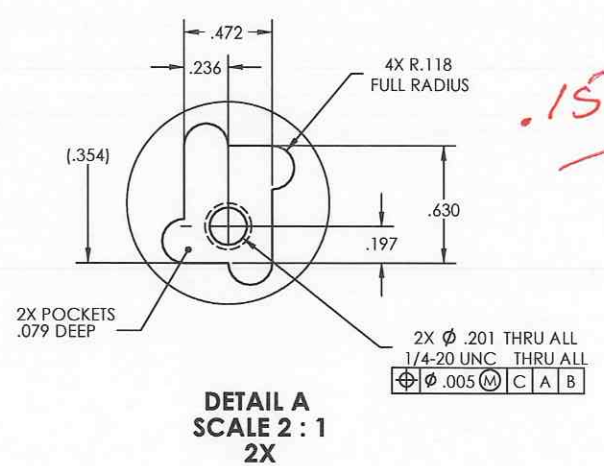
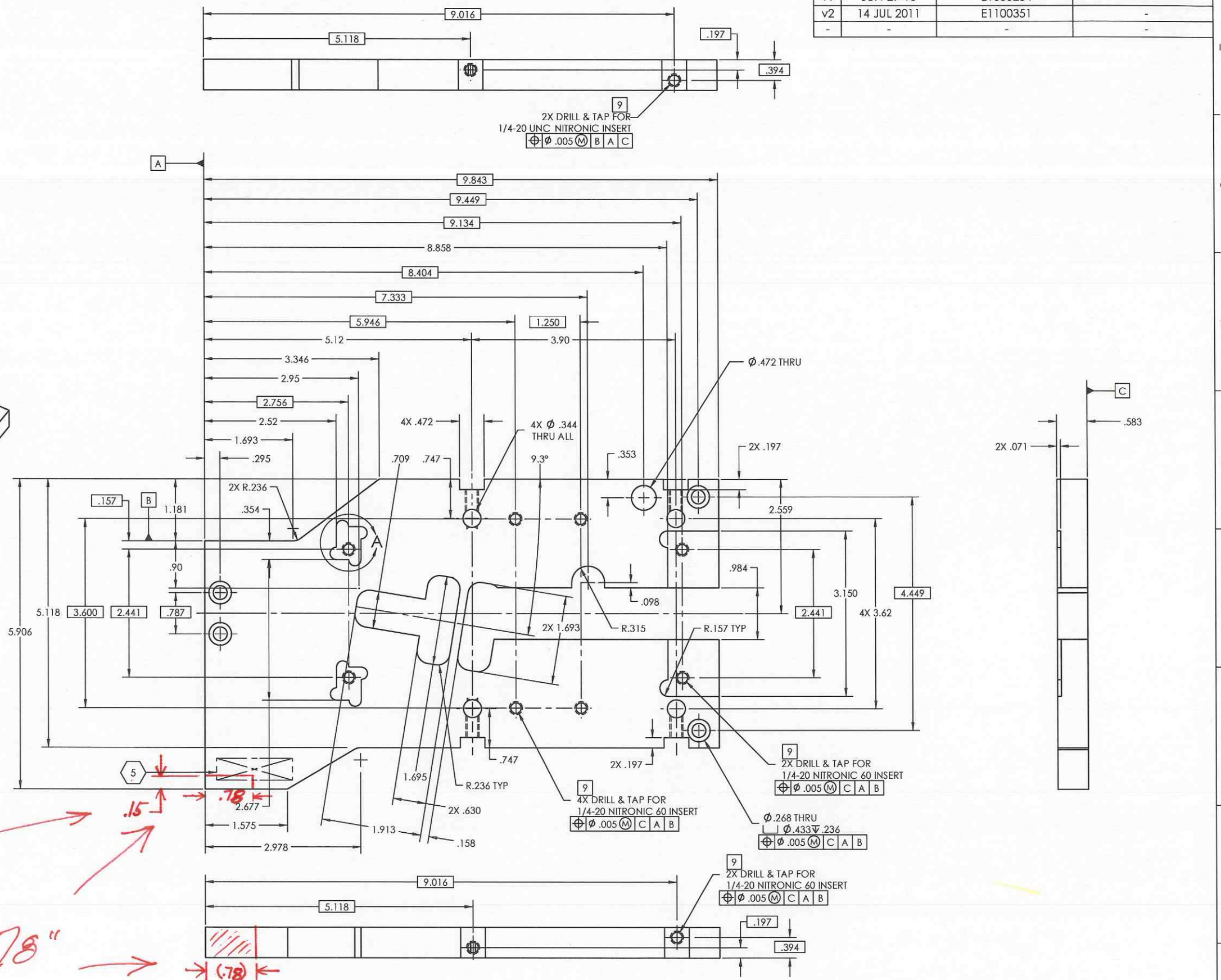
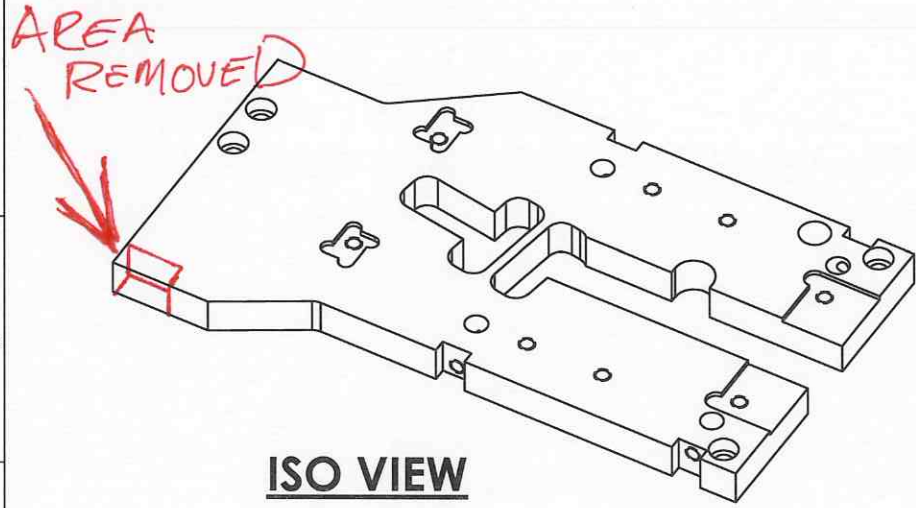

.15"

.15"

.78"

(.78)

DIMENSIONS ARE IN		NOTES AND TOLERANCES: (UNLESS OTHERWISE SPECIFIED)		CALIFORNIA INSTITUTE OF TECHNOLOGY MASSACHUSETTS INSTITUTE OF TECHNOLOGY		PART NAME							
TOLERANCES:	XX ± .010	1. INTERPRET DRAWING PER ASME Y14.5-1994.	2. REMOVE ALL SHARP EDGES, R.02 MIN.	ADVANCED LIGO		αLIGO INTERMEDIATE MASS TOP PLATE							
	XXX ± .005	3. DO NOT SCALE FROM DRAWING.	4. ALL MACHINING FLUIDS MUST BE FULLY SYNTHETIC, FULLY WATER SOLUBLE AND FREE OF SULFUR, SILICONE, AND CHLORINE.					DESIGNER	K. MALAND	22 FEB 2010	SIZE	DWG. NO.	
ANGULAR ± 5°				MATERIAL	304 SSSL	FINISH	32 μinch	DRAFTER	I. ROMERO	4/14/10	D	D1000393	
				SYSTEM		SUB-SYSTEM		CHECKER	K. MALAND	4/14/10	SCALE: 1:1	PROJECTION:	SHEET 1 OF 1
				NEXT ASSY		D1000442		APPROVAL	K. MALAND	4/14/10			