

PUM Driver State Machine

T1100507-v8

Filter Notation
[zero (Hz) : pole (Hz)]

STATE 1: Acquire OFF, Lowpass OFF

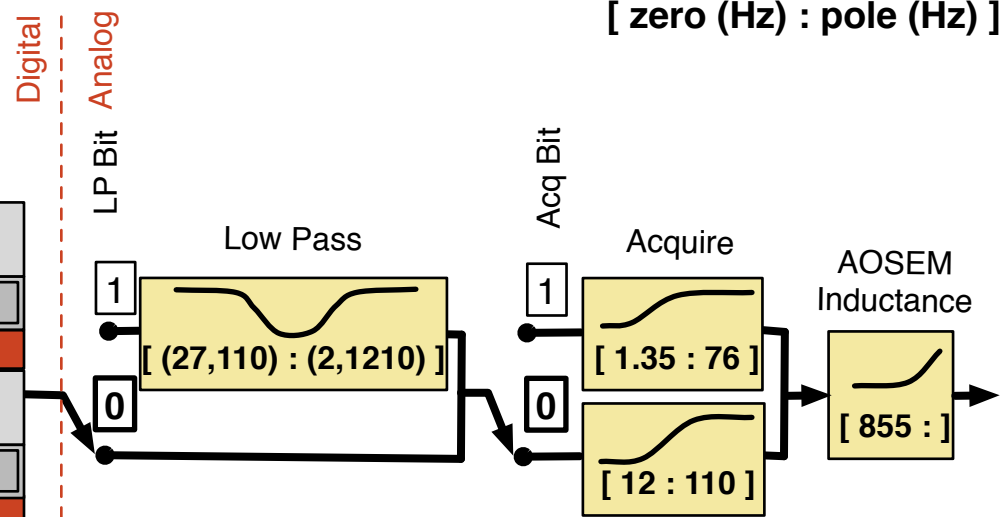
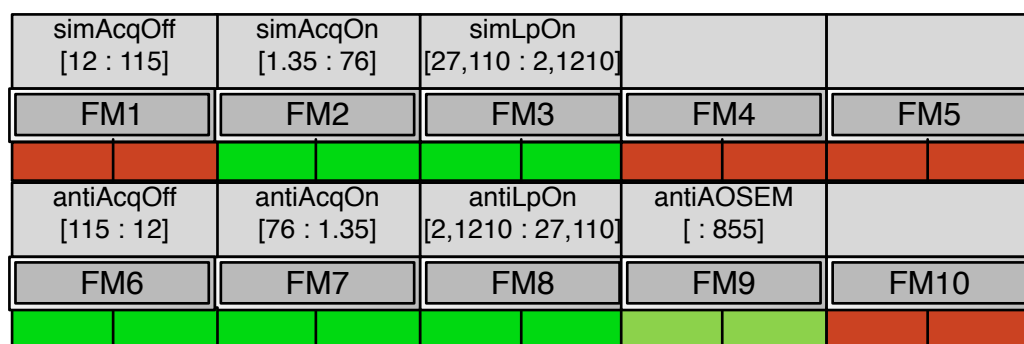

STATE 2: Acquire ON, Lowpass OFF

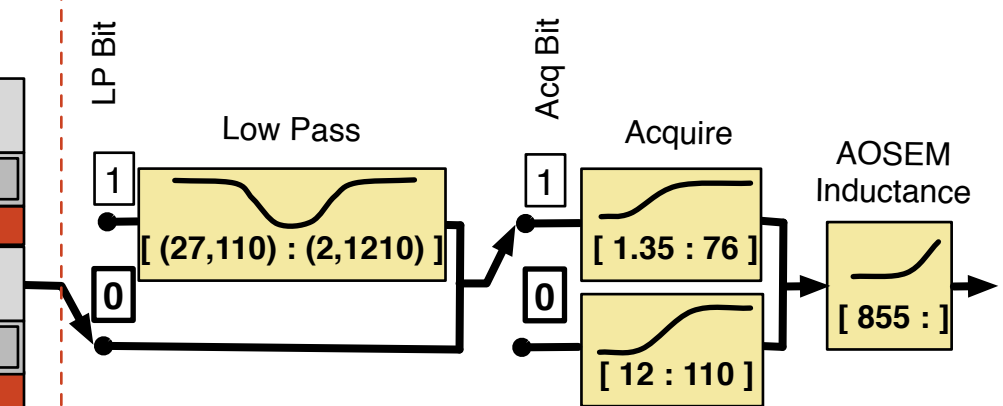
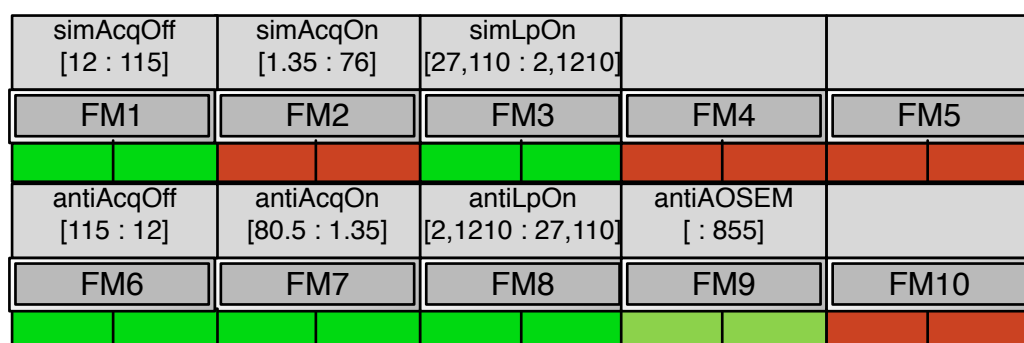

STATE 3: Acquire OFF, Lowpass ON

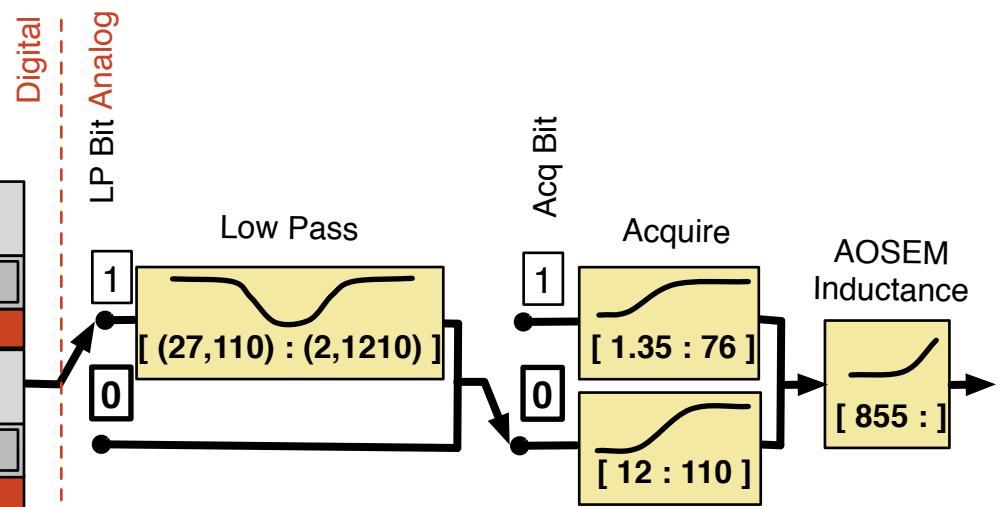
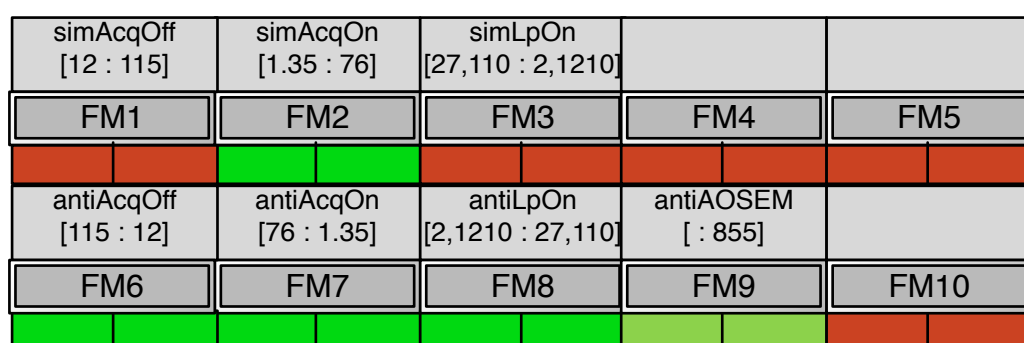

STATE 4: Acquire ON, Lowpass ON

